

CHELSEA® 249V SERIES

PTO w/ Vane Pump for Ford 6R140 Transmission

Chelsea's 249V Series PTO fits both the 4 x 4 and 4 x 2 Ford Super Duty with the TorqueShift™ 6 Automatic Transmission. This unique design concept will provide a PTO that is best in class for pressure, flow, and noise reduction. The 249V provides flows up to 35 GPM at 3500 PSI continuous pressure. This PTO also features a Patented Noise Suppression System. The combination of the Chelsea 249 Series and the Parker Denison T6C vane pump will provide greater flows and pressures that are not available anywhere else.

Applications:

- Aerial
- Tow & Recovery
- Fire & Rescue
- Water Drilling
- Truck Mounted Cranes

Product Features and Benefits:

- Pump flows up to 35 GPM at 3500 PSI – Integrated design provides maximum power in a small package.
- Simple – PTO, pump, wiring harness and shift kits available under one part number and package.
- Noise Suppression System – Provides quiet PTO applications on Ford Trucks equipped with a 6 speed transmission.
- SmartStart Available – Shock load dampening feature to protect driven equipment.
- Installation – Eliminates costs and saves time.
- Single Hose Connection and Integrated Actuation Valve – Single hose for the PTO simplifies installation and reduces installation time along with eliminating leak paths.
- Intermittent Torque Rating of 200 lbs-ft – 58 Horsepower @ 1200 Engine RPM.
- Two Year Warranty – Greater bearing capacity. Larger gear width and greater clutch engagement surface provide a robust design.

U.S. Patent No. 9,494,227 B2

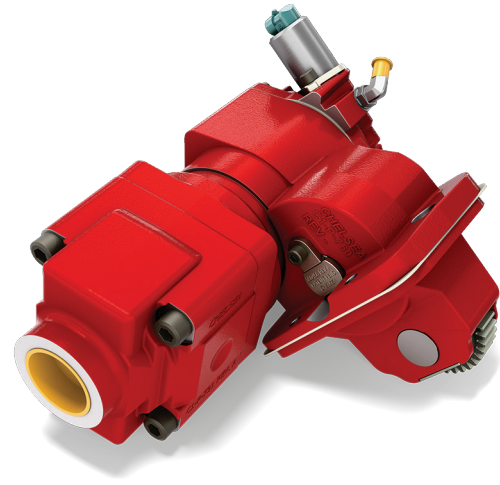

249V Series



249V Series Power Take-Off – Ford 6R140 6-Speed Transmission

Model Number Designator

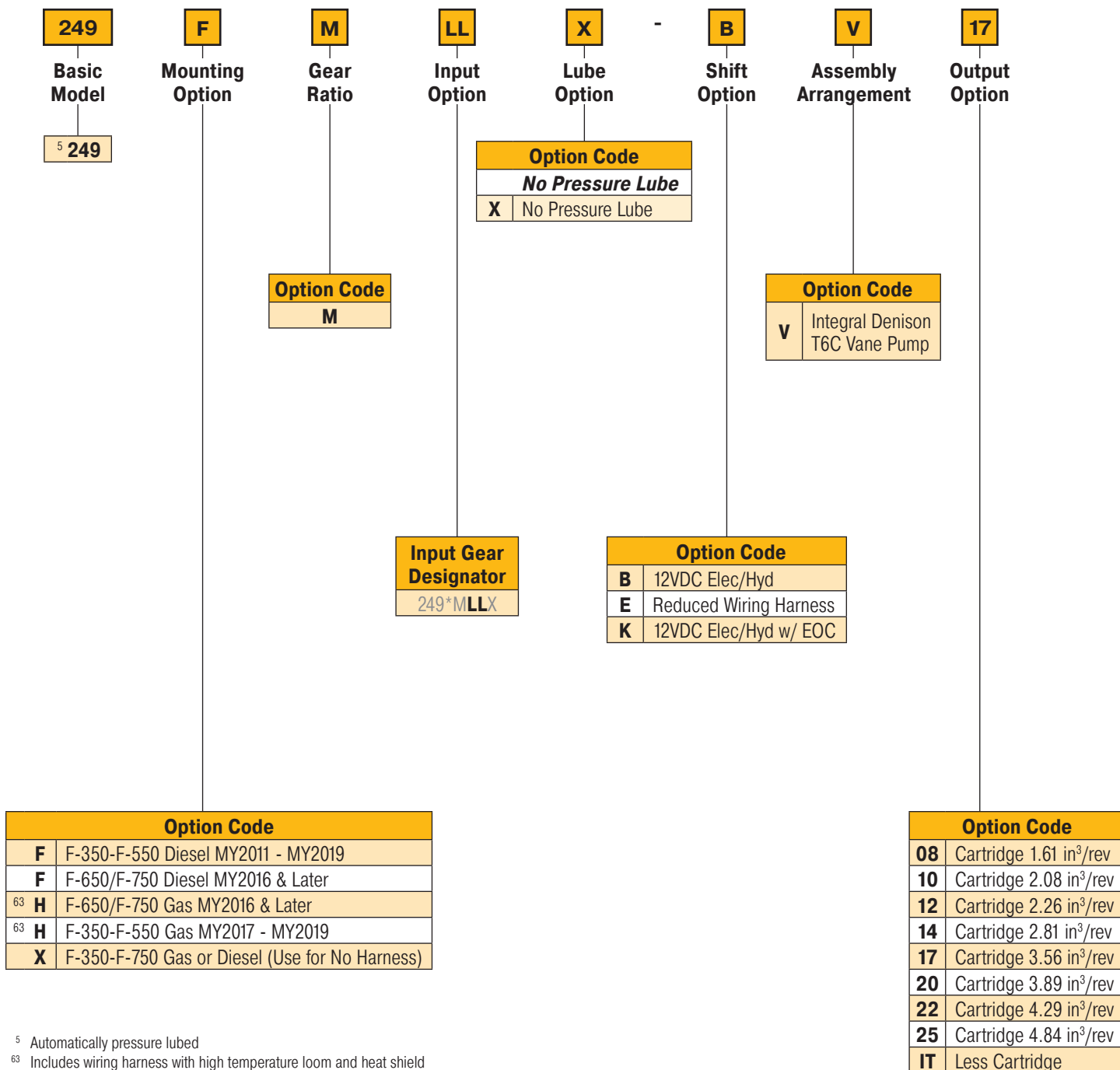

⁵ Automatically pressure lubed

⁶³ Includes wiring harness with high temperature loom and heat shield

249V Series Power Take-Off – Ford 6R140 6-Speed Transmission Specifications

Chelsea 249V Integral Vane Pump Data for 4x2 or 4x4 Vehicles										
Option Code w/ PTO	Chelsea Pump Cartridge Number	Displacement (in ³ /rev)	GPM (D)	Pump HP (D)	Torque lb-ft (D)	Pressure PSI		Pump Speed RPM		Max Speed RPM
						Intermittent	Continuous	Min.	Max	Engine (B)
08	380418-08	1.61	9.33	19	67	4,000	3,500	400	2,800	2,015
10	380418-10	2.08	12.06	25	87	4,000	3,500	400	2,800	2,015
12	380418-12	2.26	13.10	27	94	4,000	3,500	400	2,800	2,015
14	380418-14	2.81	16.29	33	117	4,000	3,500	400	2,800	2,015
17	380418-17	3.56	20.64	42	149	4,000	3,500	400	2,800	2,015
20	380418-20	3.89	22.55	46	163	4,000	3,500	400	2,800	2,015
22	380418-22	4.29	24.87	51	179	4,000	3,500	400	2,800	2,015
25	380418-25	4.84	28.06	57	202	4,000	3,500	400	2,800	2,015
157	380418-157	–	–	–	–	4,000	3,500	400	2,800	2,015

(A) GPM & Pump Input HP @ 1200 Engine RPM (1488 PTO Output RPM - 124% Ratio) & Continuous Pressure Rating with 90% efficiency rating considered.
 (B) Max Engine Speed = (Max Pump Speed)/(1.24) for PTO Ratio Increase. Max Speed determined by Max PTO output speed of 2500.
 (D) GPM & Pump Input HP @ 1200 Engine RPM (1488 PTO Output RPM - 124% Ratio) & 2000 PSI Continuous Pressure Rating. See leakage chart for additional flow losses at other pressures.
CAUTION: 249V Pump Options: The PTO drive gear delivers up to 250 lb-ft torque to the aftermarket PTO, and can manage the heat of 40 HP continuously. Higher horsepower can be delivered, but for shorter durations depending on the amount of power required. Ref: Ford Body Builders Manual; TorqShift® Automatic Transmission.
NOTE: Refer to Chelsea Owner's Manual HY25-1FRD-M1/US for complete vane pump information.

FORMULAS:
 GPM = Cu. In. x .004329 = G/rev x 1488 RPMs x .90 efficiency
 HP = (GPM x Max PSI)/1714
 Torque = (HP x 5252)/1488 RPMs

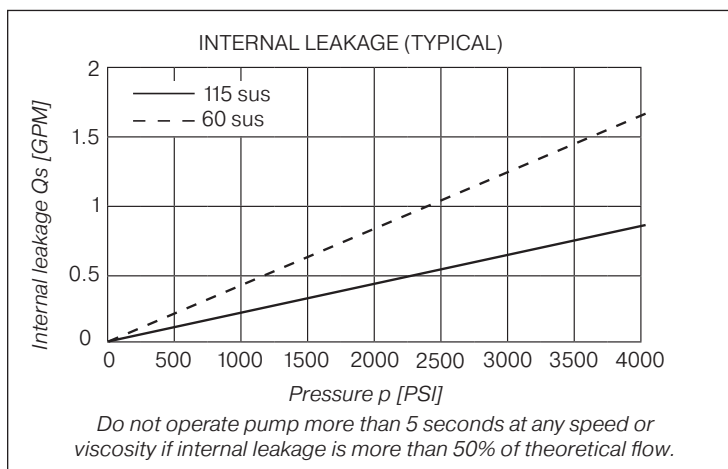

249V Series Power Take-Off – Ford 6R140 6-Speed Transmission

Dimensions – For PTO output information see application catalog

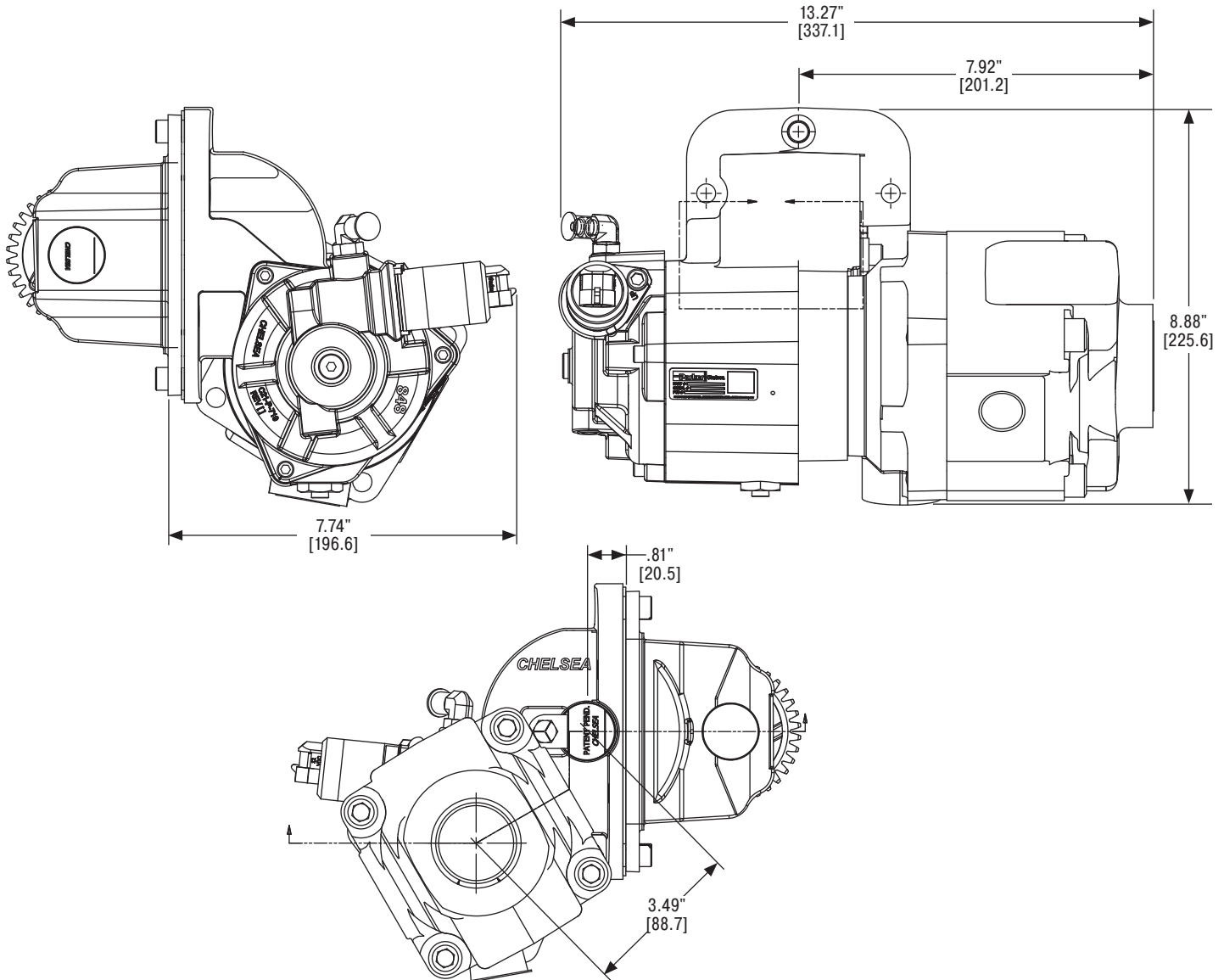

Parker Hannifin Corporation
Chelsea Products Division
8225 Hacks Cross Road
Olive Branch, MS 38654 USA
phone 1-888-PH4-TRUK (1-888-744-8785)
chd_support@support.parker.com
www.parker.com/chelsea

HY25-0185-B1/US November 2025

© 2025 Parker Hannifin Corporation

